

TrueShield Mobile Surveillance Trailer

Leasing Return Guide

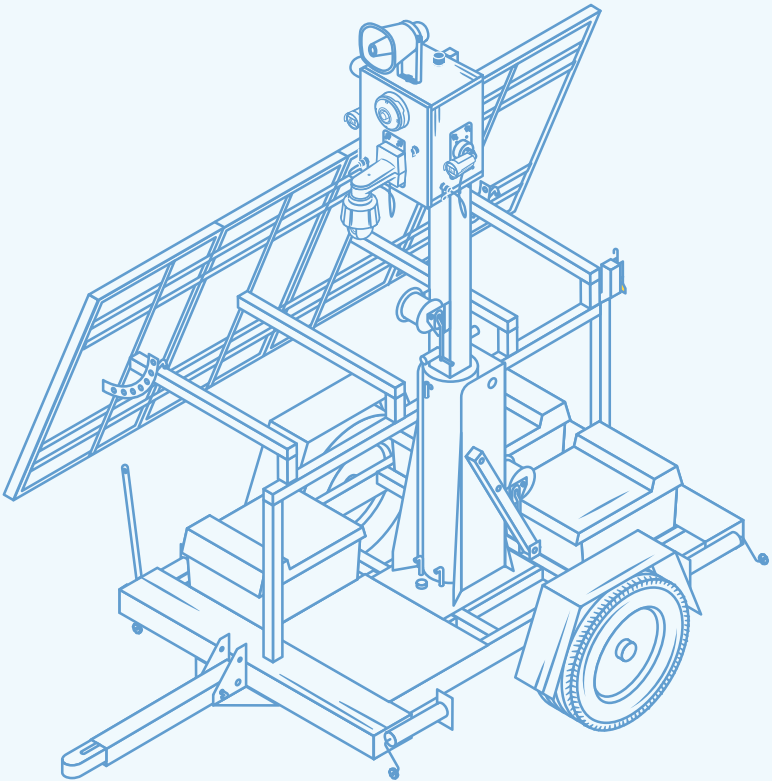

Assembled Unit

Pro model depicted.

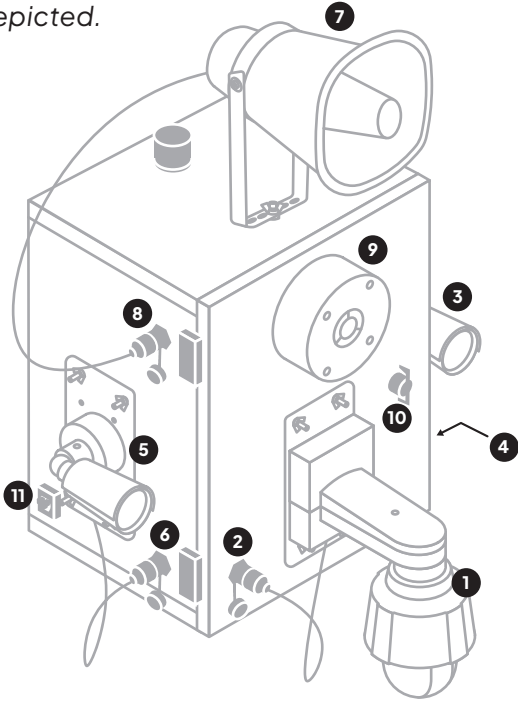

- 1. Front camera
- 2. Front camera port
- 3. Right camera
- 4. Right camera port
- 5. Left camera
- 6. Left camera port
- 7. Bullhorn
- 8. Bullhorn port
- 9. Strobe and siren
- 10. Enclosure door lock
- 11. 110V power input

Trailer Return

This guide will walk you through how to prepare your trailer and security solution for shipment. If you haven't already done so, reach out to TrueLook's Leasing Department to schedule your leased trailer's return by emailing leasing@truelook.com.

Unlimited Support

If you have any questions or issues regarding the preparation of this equipment for shipment, please don't hesitate to contact our Customer Support team.

Email support@truelook.com

You can also submit a support request online at:
support.truelook.com/contact-support

Solar Panels

Step 1 Angle the panels to lay vertical by removing the panel angle adjuster bolt and placing it in the corresponding hole.

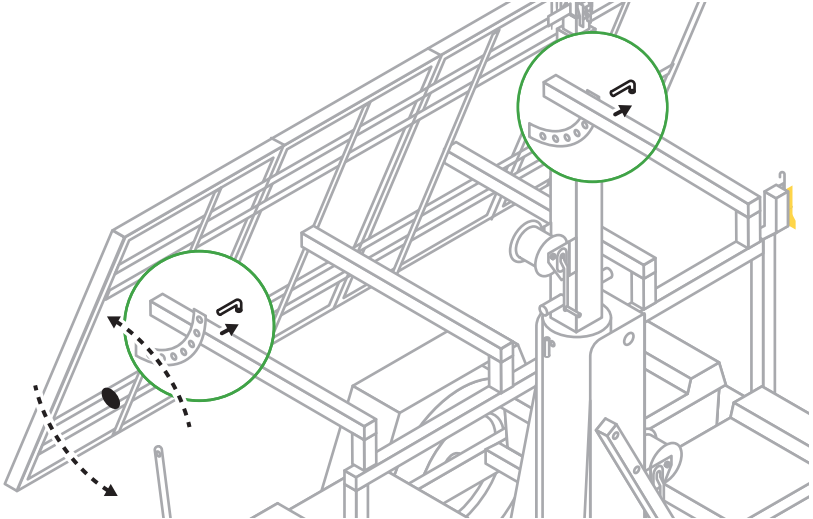

Preparation

Step 2 Secure the solar panels to the travel arms by attaching the pins.

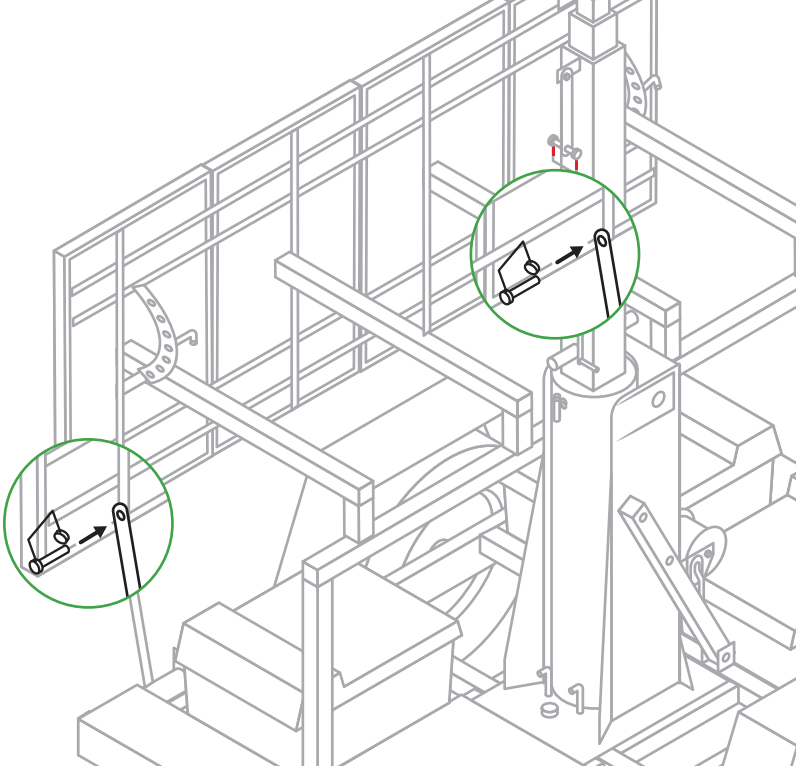

Trailer Mast

Step 1 Reposition the mast back to its original position by removing the rotation lock bolt and rotating the mast, aligning the red arrows to point at each other. Re-tighten the rotation lock bolt.

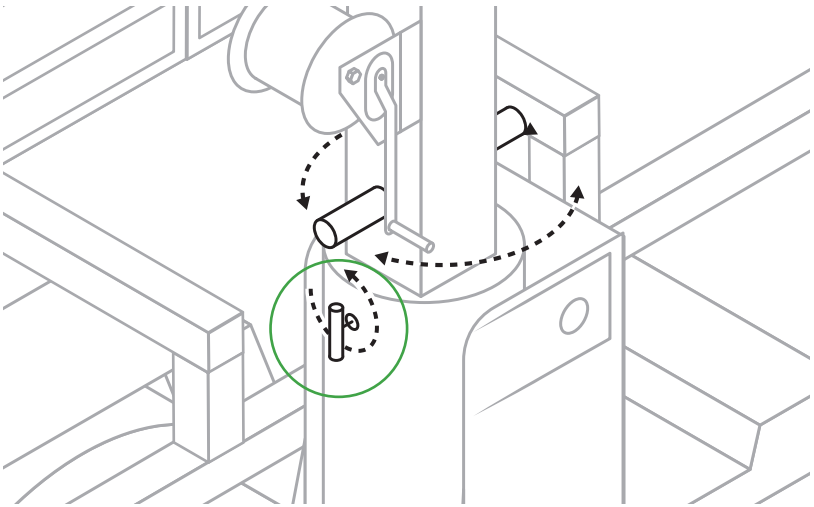

Preparation

Step 2 Use the higher winch to lower the extendable portion of the mast until fully collapsed.

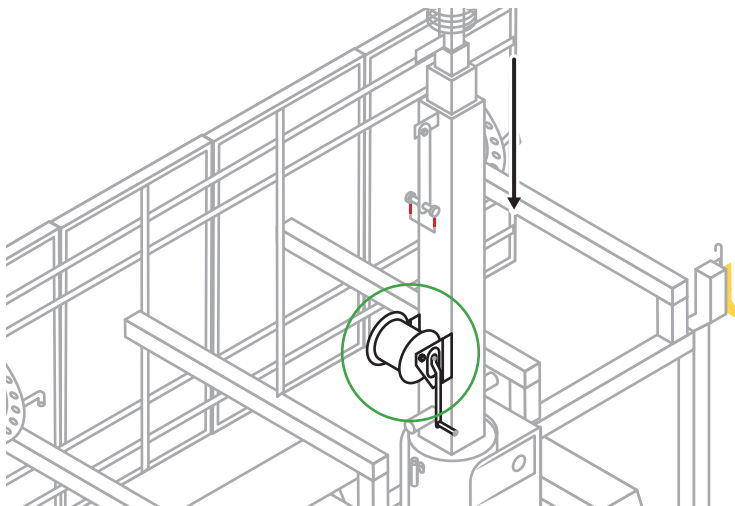

Step 3 Remove the two locking pins from the holes at the base of the mast.

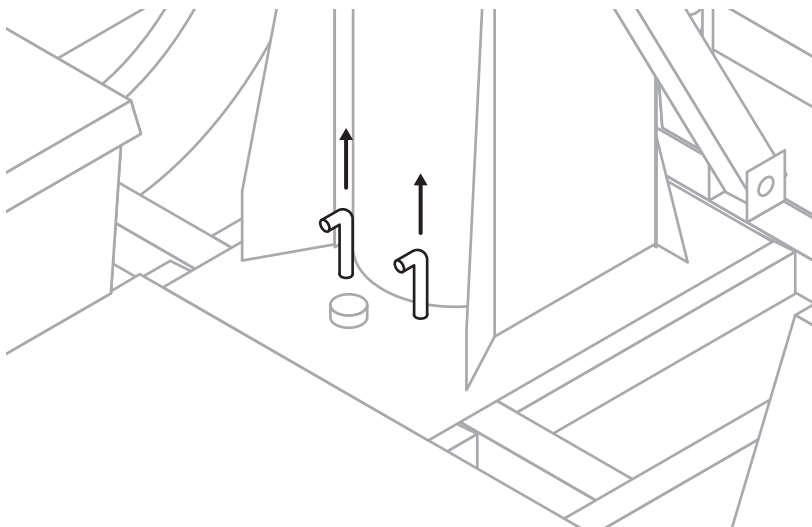

Preparation

Step 4 Use the lower winch to position the mast to lie horizontal.

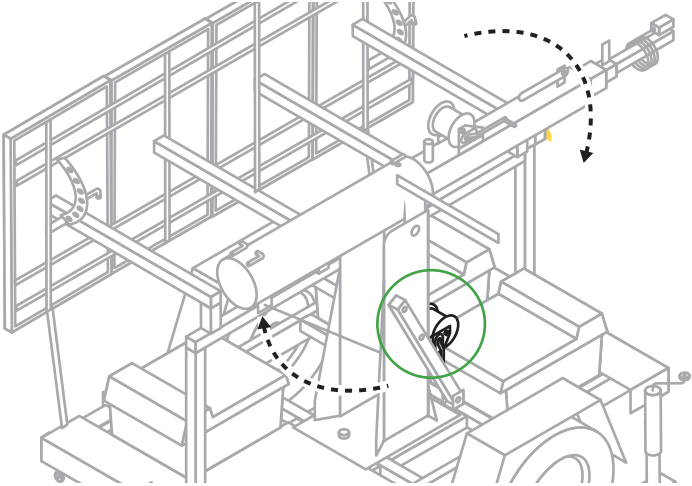

Step 5 Insert the red lock pin and hook the wire to secure.

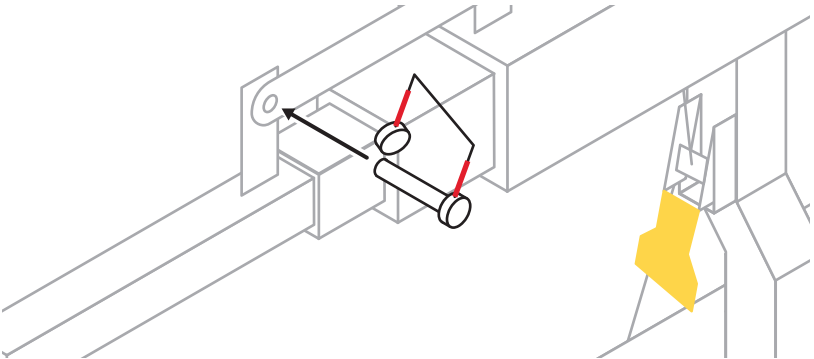

Preparation

Step 6 Lift the yellow lock handle to position the metal hook, then lower the handle to secure the hook into the hole.

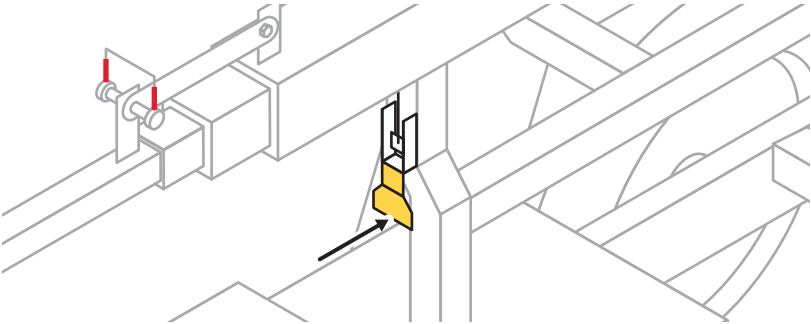

Uninstalling TrueShield

Warning: Safely removing the TrueShield unit requires at least two people. Do not attempt removing it alone.

Step 1 Remove the power cable from the 110V power outlet at the top of the mast and from the outlet on the side of the TrueShield enclosure.

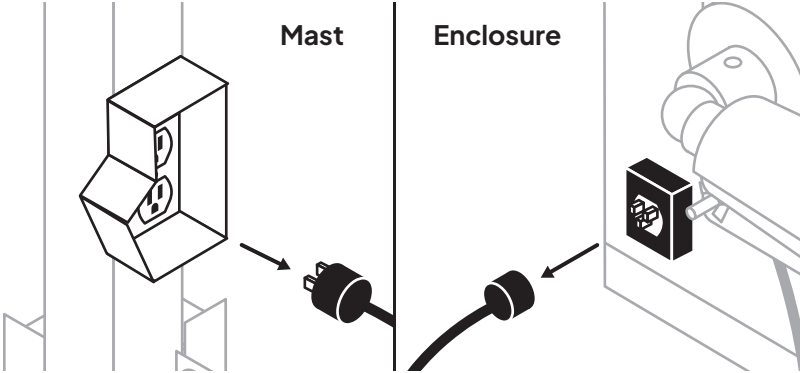

Preparation

Step 2 Disconnect the horn and cameras from the unit by unscrewing the protective caps on the end of the connectors and unplugging the connectors.

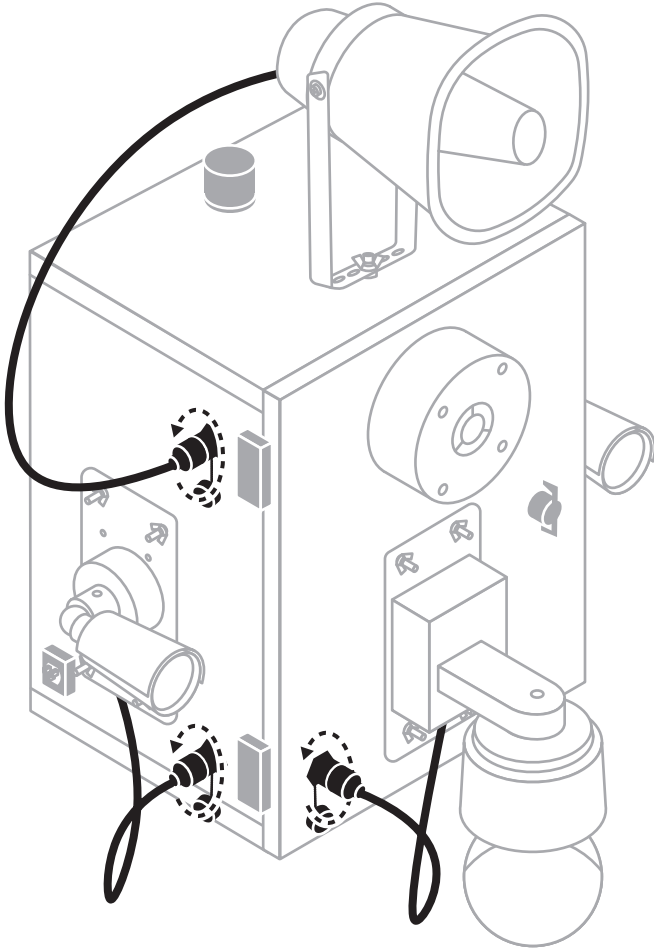

Preparation

Step 3 Screw the protective caps that are hanging from the enclosure onto each input.

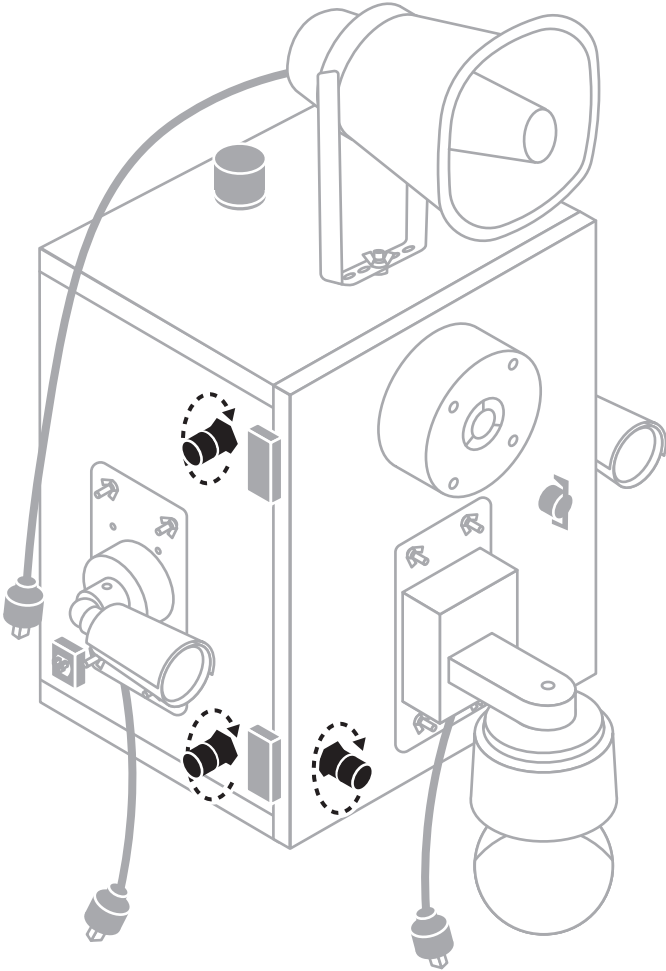

Preparation

Step 4 Remove the horn and cameras from the unit by loosening the wing nuts off the mounting studs. Store the wing nuts in the provided plastic bag

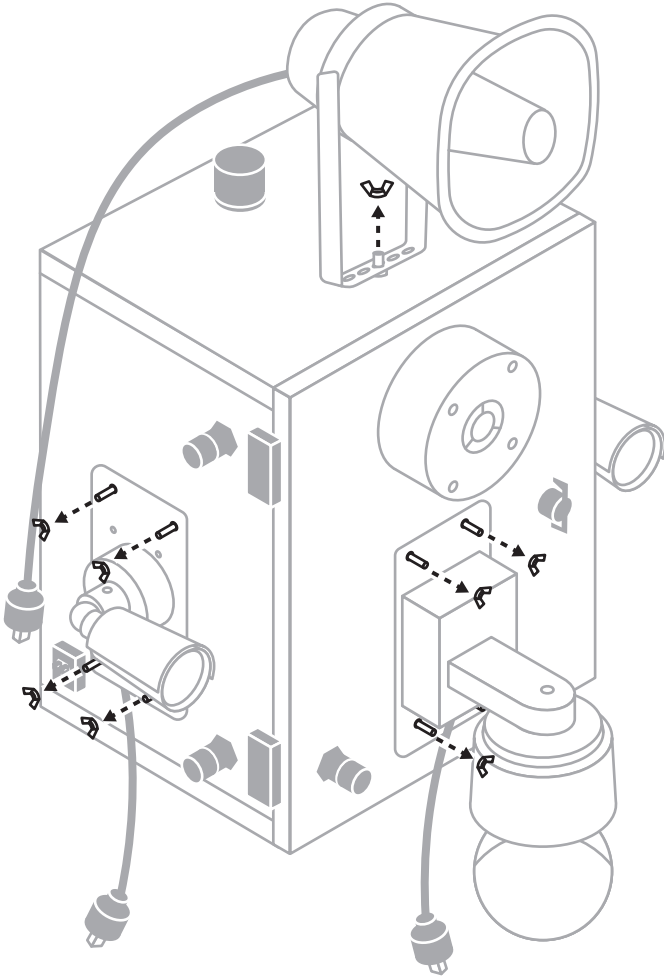

Preparation

Step 5 Using a microfiber cloth, dry off all equipment thoroughly to avoid water damage while in transit. Ensure all equipment is completely dry before placing inside the hard case.

Step 6 Place the lens caps onto the Fixed 4K IR cameras.

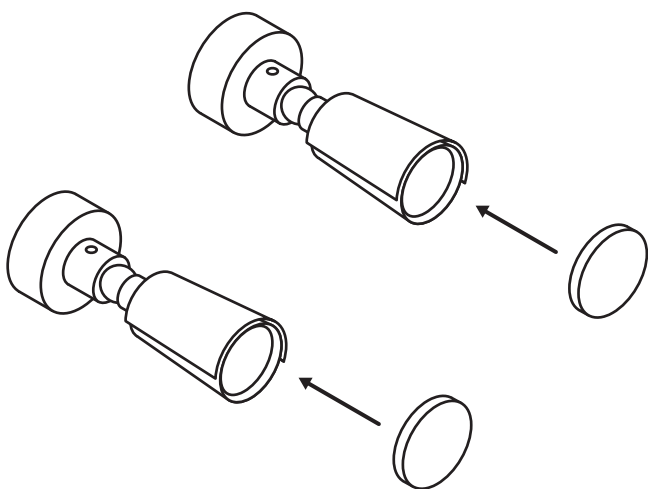

Preparation

Step 7 Separate the lower mounting bracket from the enclosure by removing the nuts on the back of the enclosure. Thread the nuts back onto the studs.

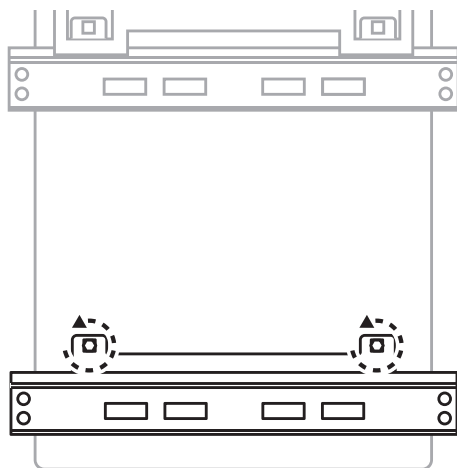

Step 8 Carefully remove the enclosure from the trailer mast by sliding it off the upper mounting bracket.

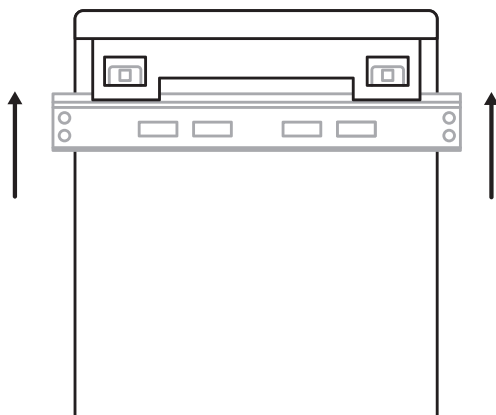

Preparation

Step 9 Open the enclosure and disconnect the red and black battery connectors.

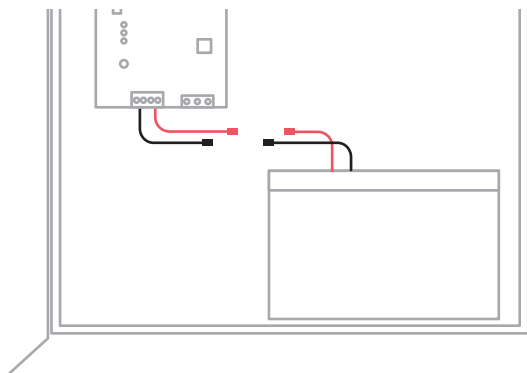

Leave the mast adapter with the mounting brackets installed on it attached to the trailer mast for return shipment.

Trailer Body

Step 1 Put the trailer tongue down by unhooking the clip and removing the pin, then lowering the trailer tongue to be horizontal. Place the pin and hook the clip to secure.

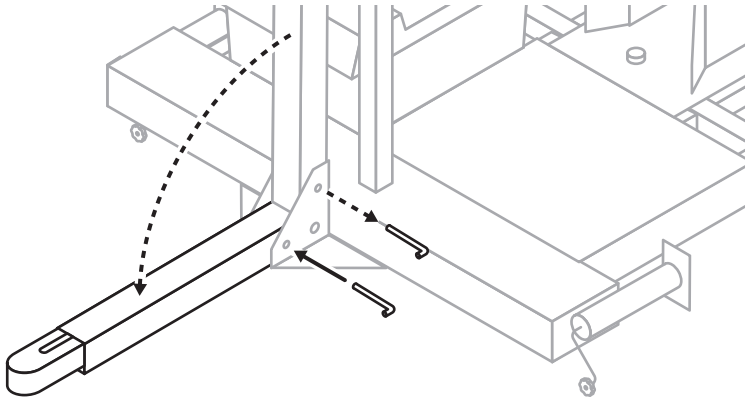

Step 2 Put jack stands up by pulling the pin and turning the jack stands horizontal to lie in line with the trailer.

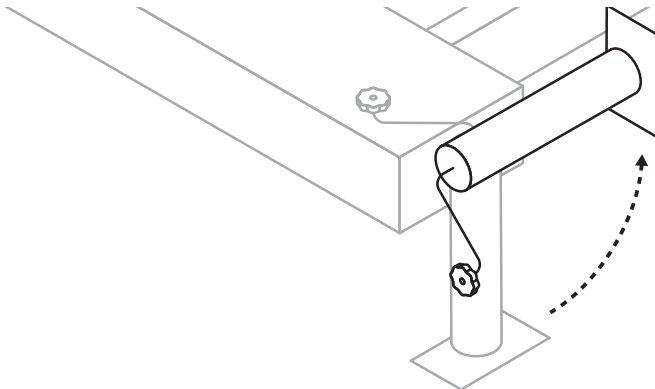

Packing

Step 3 Chock all tires on both sides. Keep the tires chocked until the delivery team arrives for trailer pickup.

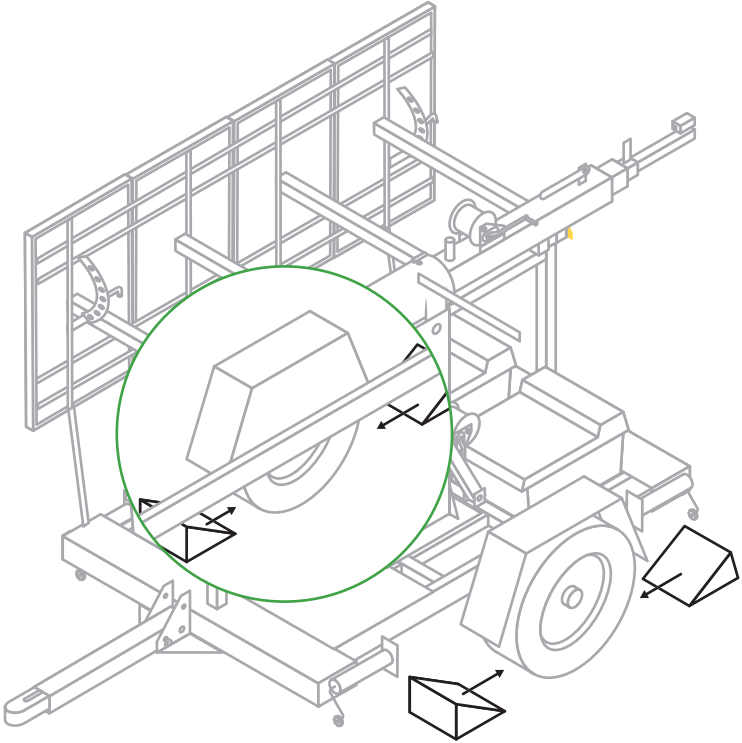

Packing into Hard Cases

Enclosure

Carefully lower enclosure into hard case with the siren facing upward.

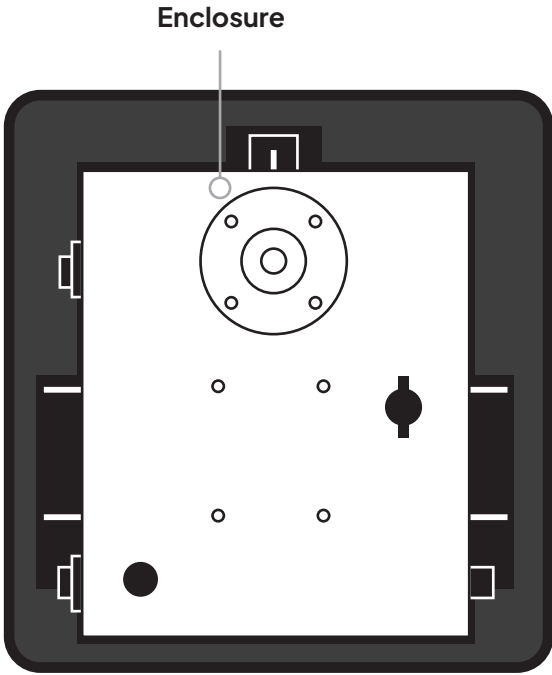

Cameras and Accessories

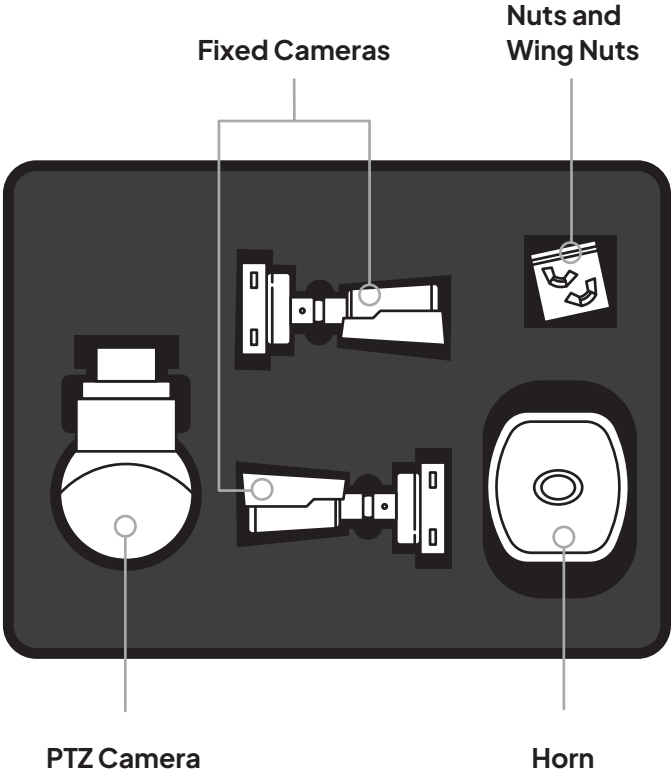

Securing Hard Cases

Step 1 Using the provided 25 feet of strap, measure out the necessary length for two straps to secure the enclosure hard case to the solar panel support structure on the back left of the trailer.

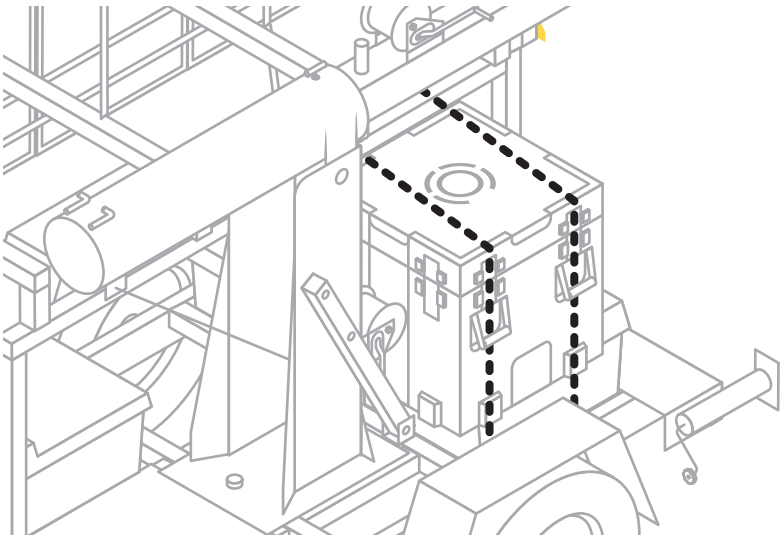

Step 2 Cut the lengths and attach the buckles to the straps.

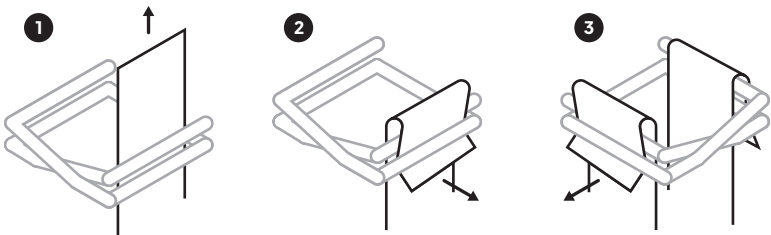

Packing

Step 3 Place the enclosure hard case on top of the back left battery compartment and secure it to the solar panel support structure with the straps threaded through the handles on the hard case.

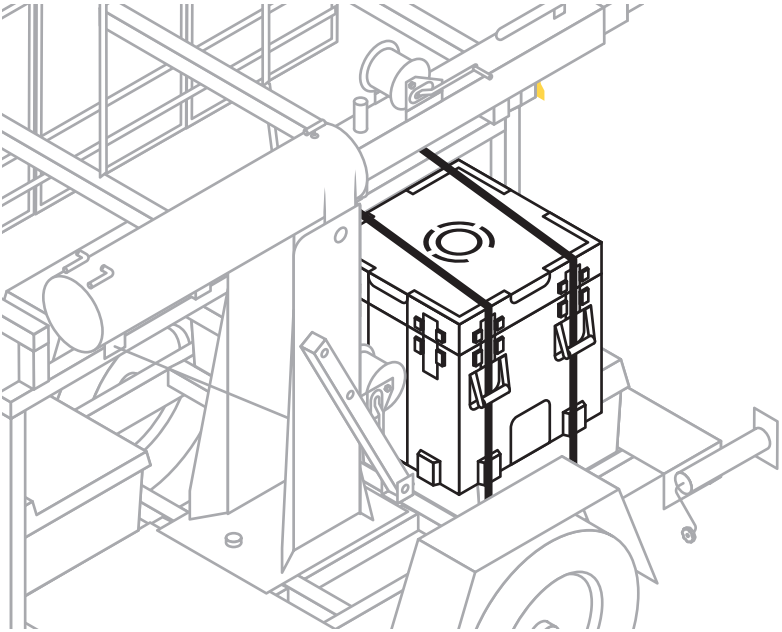

Step 4 Repeat steps 1 and 2 to prepare two straps to secure the camera and accessories hard case to the front left of the trailer.

Packing

Step 5 Place the camera and accessories hard case onto the front left of the trailer and secure it to the trailer with the straps threaded underneath the trailer body.

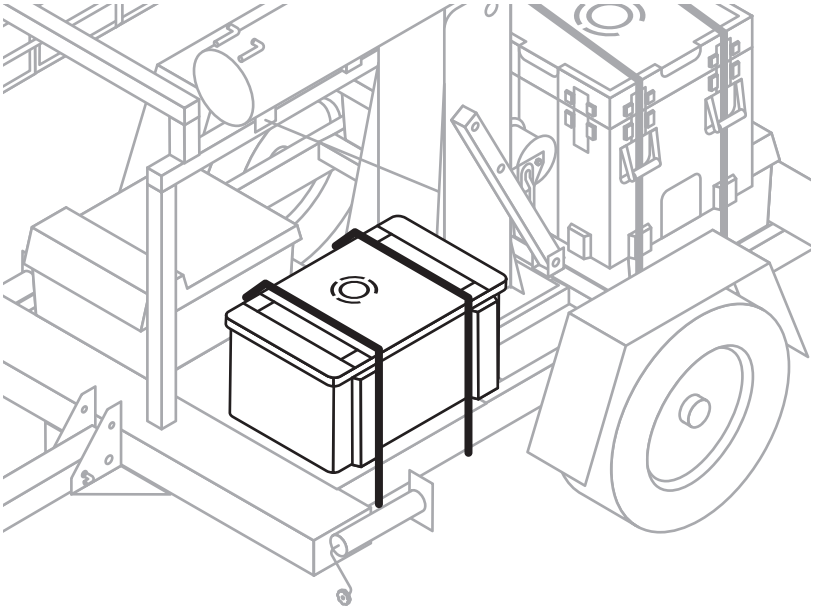

Note: You may have extra unused materials. Please wrap up any unused strap length and secure it with zip ties, then pack into a battery compartment.

Review

Warning: Please note that all equipment is your responsibility until it returns to our warehouse.

Email pictures of the trailer from all four sides to leasing@truelook.com. Our team will confirm if it's ready to ship or provide suggestions for more secure shipping.