

Solar Equipment

Leasing Return Guide



Preparation

STEP 01

Using the provided 86 feet of strap, cut the following lengths:

2 Battery Setup

- 2 115" straps
- 2 105" straps
- 2 80" straps
- 1 145" strap
- 2 140" straps

4 Battery Setup

- 2 115" straps
- 2 110" straps
- 3 145" straps

Note: You may have extra unused materials depending on which solar model you have.

STEP 02

Add buckles to each strap.

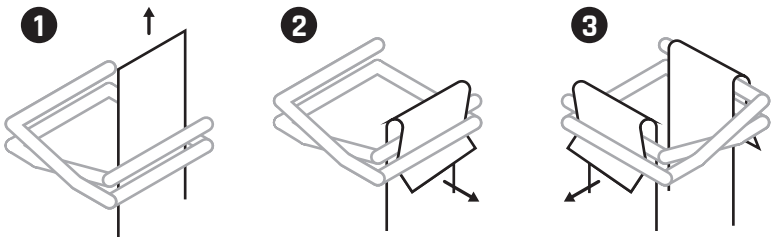

Solar Panels

STEP 01

Starting with the pallet the hardware was delivered on, place a piece of cardboard on the pallet to prevent the solar panels from falling through.

STEP 02

Place the solar panels face to face with a protective layer of cardboard or bubble wrap between them.

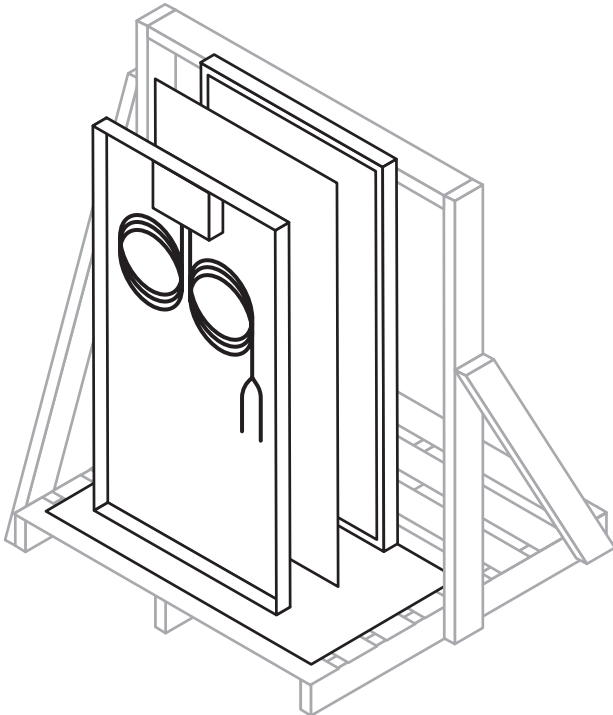

PACKING

STEP 03

Using the two 115" buckle straps, secure the panels to either side of the upright wooden structure.

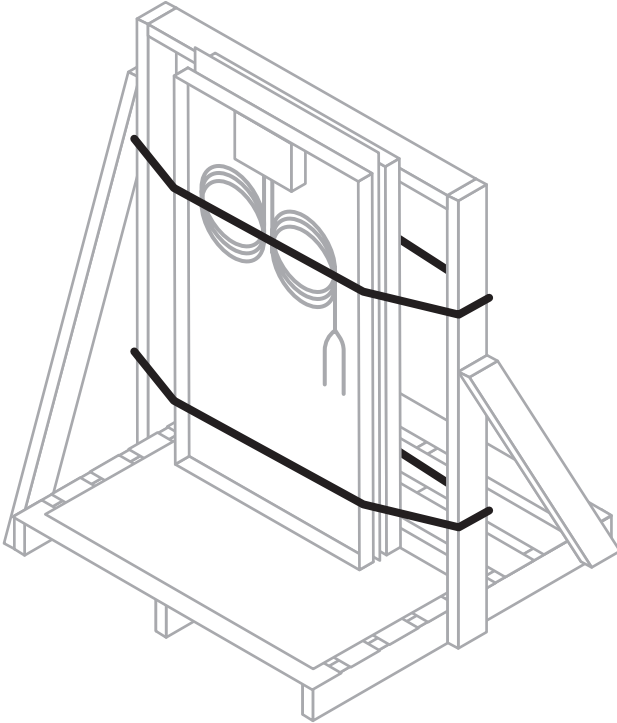

STEP 04

Use zip ties to secure cables to themselves.

PACKING

STEP 05

Stack brackets according to their size and secure together with zip ties.

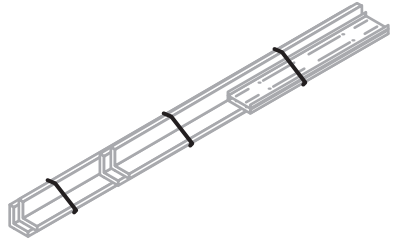

STEP 06

Attach brackets to the upright wooden structure with zip ties. Ensure they're secured on the side with the cardboard so they don't slip through the pallet.

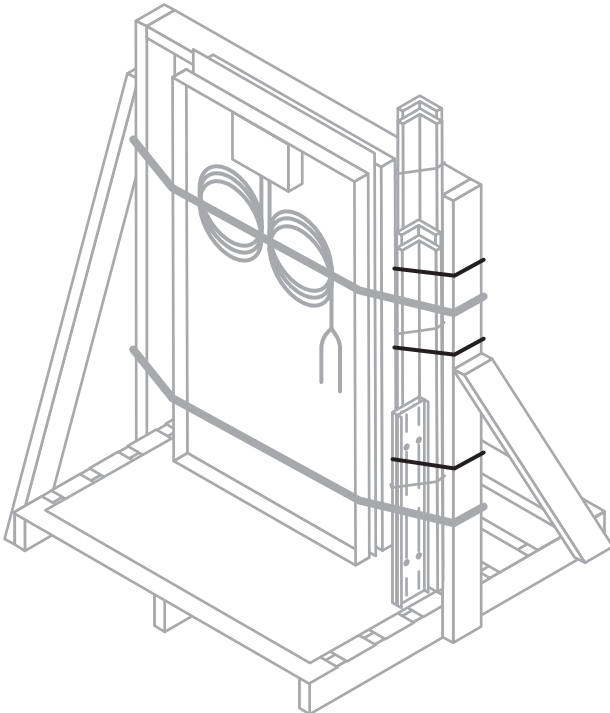

Battery Enclosure, Batteries, & Hard Case

2 Battery Setup

STEP 01

Place bracket hardware inside the battery enclosure.

STEP 02

Place the battery enclosure logo up and centered on the opposite side of the panels. Ensure the battery enclosure does not hang over the edge of the pallet.

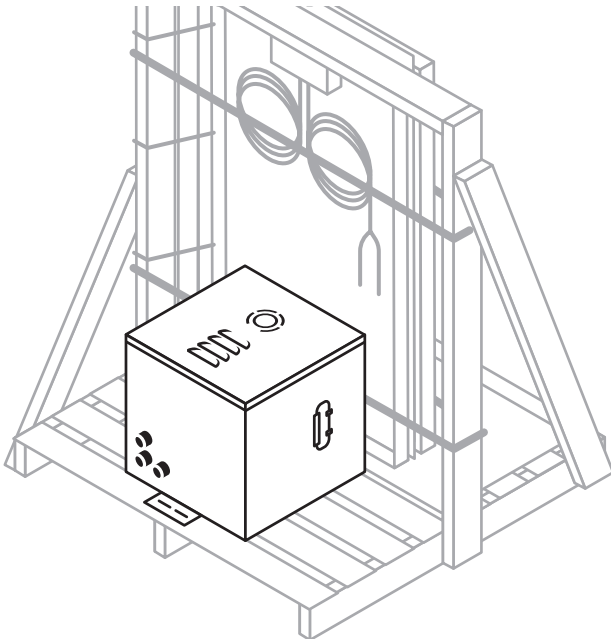

PACKING

STEP 03

Using the two 105" buckle straps, secure the battery enclosure to the pallet with the straps going vertically across the top.

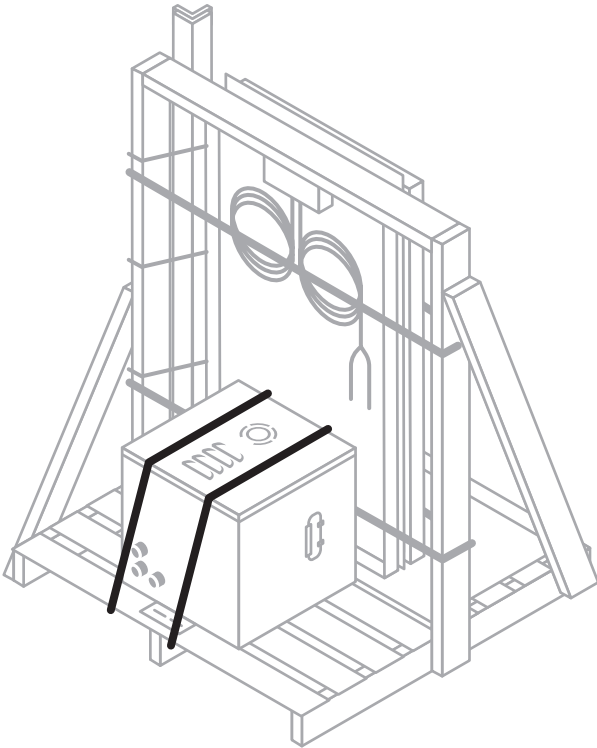

PACKING

STEP 04

Place one battery on each side of the battery enclosure and secure them with the two 80" buckle straps going vertically across the tops.

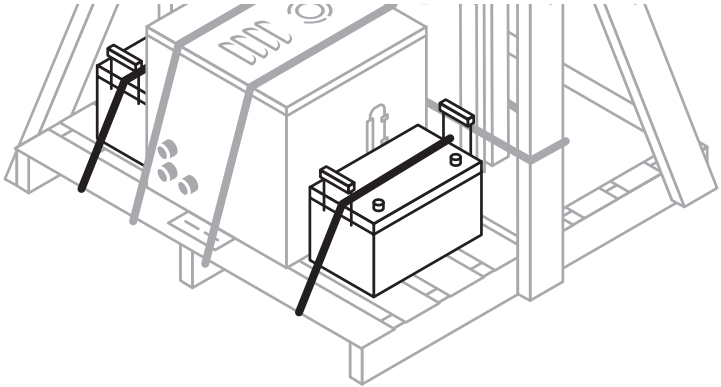

STEP 05

Secure the battery enclosure and batteries with the 145" buckle strap going horizontally across the tops.

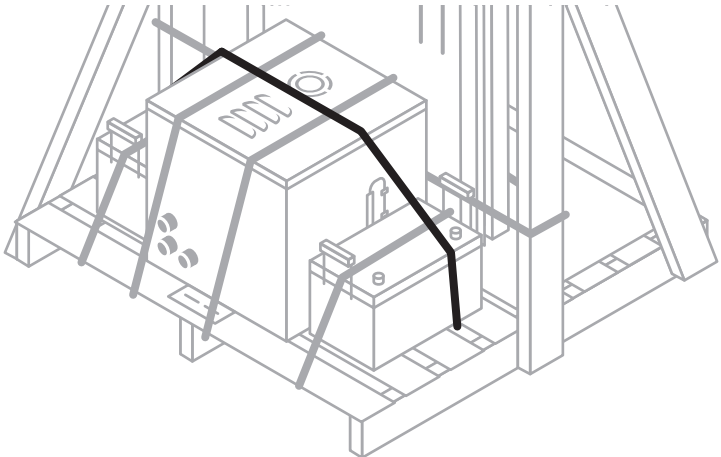

PACKING

STEP 06

Follow the instructions in the **110V and Solar Cameras Leasing Return Guide** to pack the camera, pole or wall mounting hardware, and any accessories securely into the hard case.

STEP 07

Place the hard case onto the pallet against solar panels.

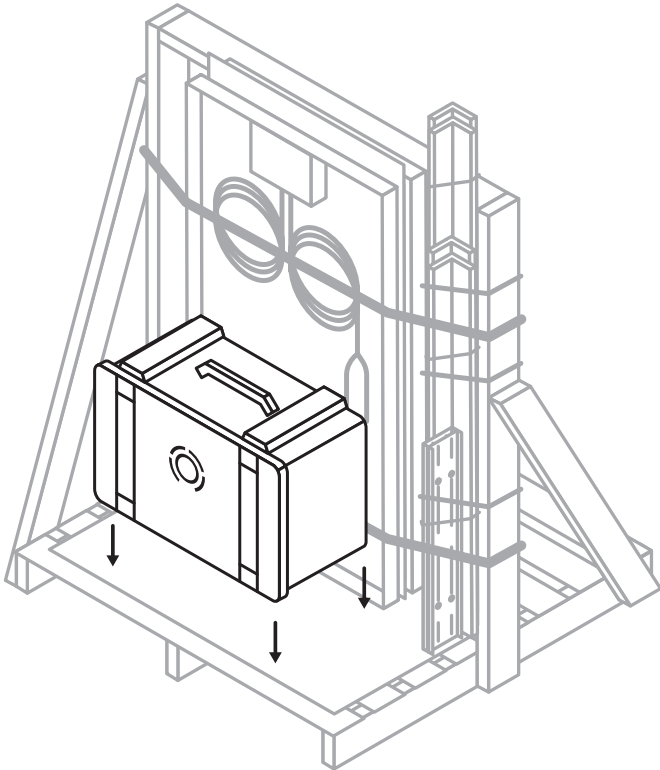

PACKING

STEP 08

Use one 140" buckle strap to secure the hard case to the upright wooden structure and the other 140" buckle strap to secure the hard case to the bottom of the pallet.

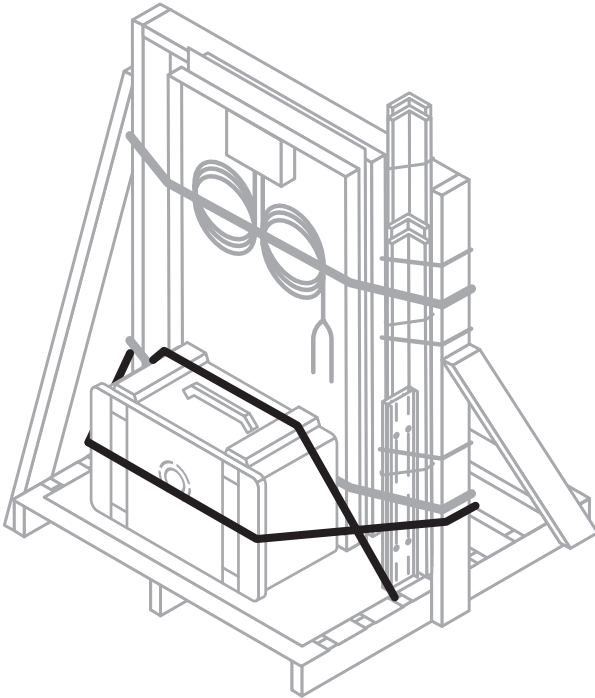

Battery Enclosure, Batteries, & Hard Case

4 Battery Setup

STEP 01

Place bracket hardware inside the battery enclosure.

STEP 02

Place the battery enclosure bottom up and centered on the opposite side of the panels. Ensure the battery enclosure does not hang over the edge of the pallet.

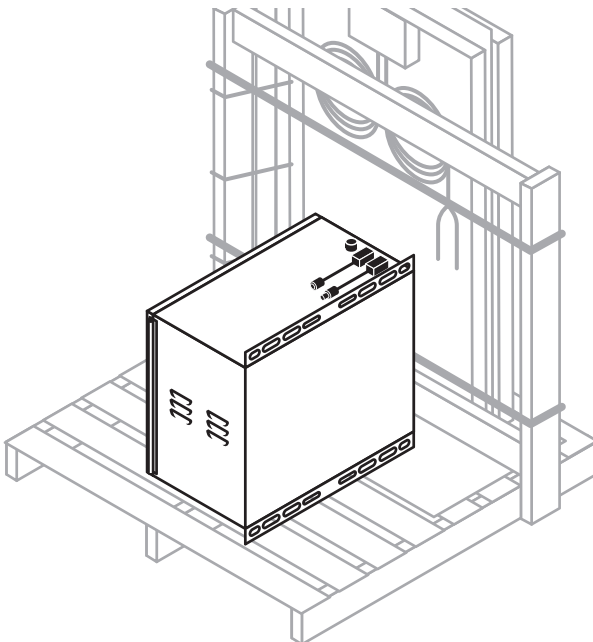

PACKING

STEP 03

Place two batteries on each side of the battery enclosure and secure them with the two 110" buckle straps going vertically across the tops.

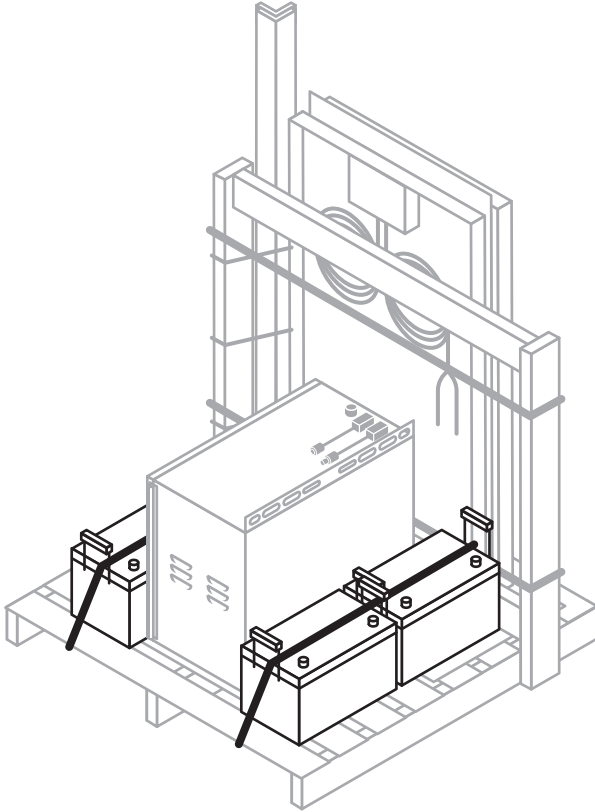

PACKING

STEP 04

Secure the battery enclosure and batteries with two 145" buckle straps going horizontally across the tops.

Thread the straps through the mounting slots on the battery enclosure for extra security.

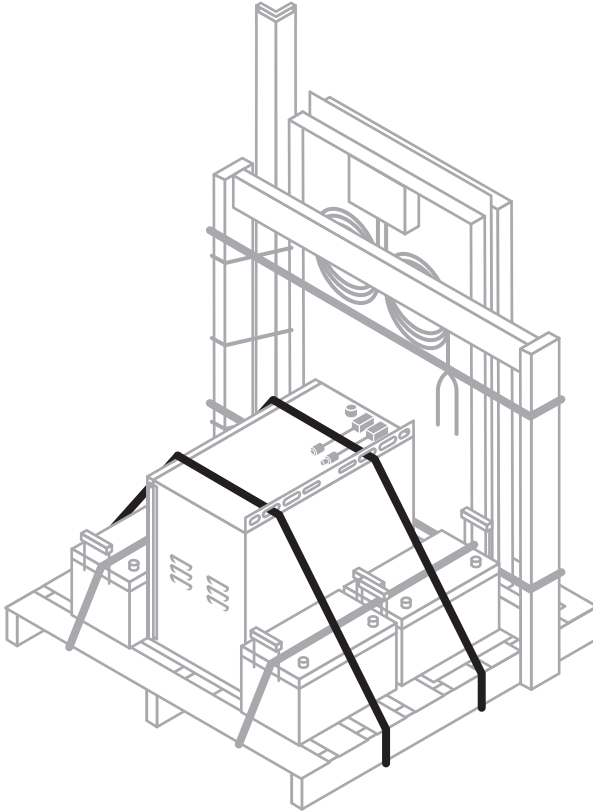

PACKING

STEP 05

Follow the instructions in the **110V and Solar Cameras Leasing Return Guide** to pack the camera, pole or wall mounting hardware, and any accessories securely into the hard case.

STEP 06

Place the hard case on top of the battery enclosure and use one 145" buckle strap to secure the hard case to the upright wooden structure.

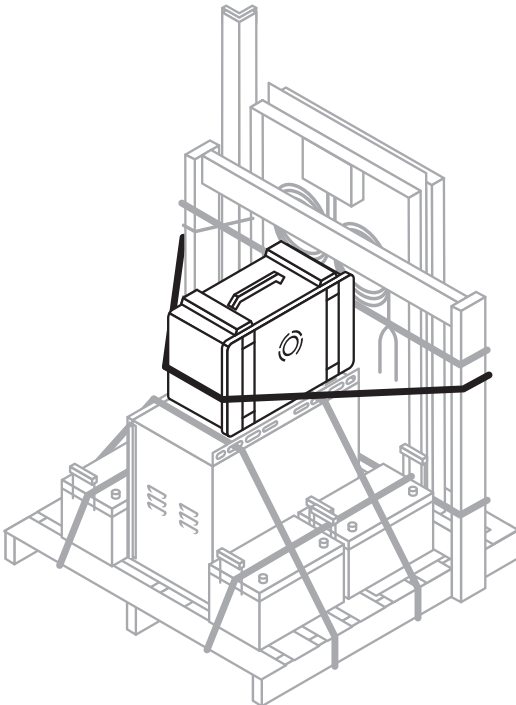

Shipping the Equipment

STEP 01

When the pallet is secure and ready to ship, email pictures of it to leasing@truelook.com.

Our team will confirm if it's ready to ship or provide suggestions for more secure shipping.

STEP 02

Once the pallet is approved to ship, it is your responsibility to schedule and ship the product. It should be shipped to:

TrueLook, Inc.
Attn: Leasing Department
305 Junia Ave
Winston-Salem, NC 27127

If you have a shipping department

If you have a shipping department and/or freight account with a shipper, use the following information to set up the shipment:

Class Code: 200

Weight: 365 lbs

Dimensions:

48"L x 40"W x 60"H

If you do not have a shipping department

If you do not have a shipping department and/or need assistance with setting up the shipment, contact the following:

Andrew Fleming at Southland Transportation

865-333-1439

truelook@sltrans.com

Southland will set the shipment up for you, and they will bill you directly for the shipment.

SHIPPING

STEP 03

Email the shipment tracking number and ship date to leasing@truelook.com.

If your shipment was set up through Southland, they will send the tracking information to TrueLook for you.



PLEASE NOTE THAT ALL EQUIPMENT IS YOUR RESPONSIBILITY UNTIL IT RETURNS TO OUR WAREHOUSE.

For assistance on how to safely return your equipment, email leasing@truelook.com or call **833-878-3566, option 2**.